

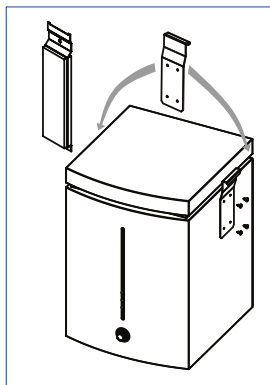

## TECHNICAL DATA

# MA-1



Optional wall mounting kit

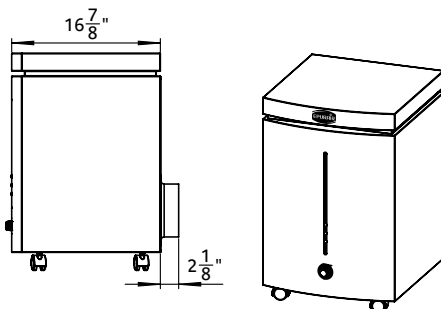
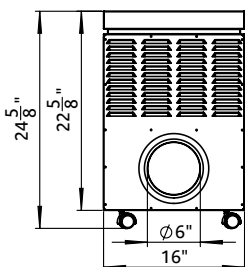

## PORTABLE TRUE HEPA FILTER

During the 2003 SARS outbreak, the Epurair MA-1 HEPA FILTER was used in hospitals throughout the province of Quebec. The MA-1 was selected because it provided an easy way to apply negative pressure into a existing room while being an efficient and cost-effective solution.

The MA-1 TRUE HEPA FILTER eliminates 99.97% of all airborne pathogens (0.3 micron) present in the air.

### CARACTERISTICS

- ULTRA QUIET : 80 CFM 30db  
125 CFM 40db  
350 CFM 52db.
- 3 years filter life expectancy.
- 5 years warranty
- Provides a powerful negative pressure when exhausted outside the room.
- Certified efficiency.
- Can be wall mounted (with optional wall mounting kit).
- CSA and UL Certified.

### HEPA (High Efficiency Particulate Air)

HEPA is a standard that was developed by the American Nuclear Energy Commission. HEPA filters are the world's most efficient air filters. They are used in hospitals, pharmaceutical preparation and electronics manufacturing to eliminate very fine particulates. To be classified as a HEPA filter, the filter must eliminate 99.97% of all 0.3 microns particles.

Distributed by:



Epurair inc.  
149 J.-A.-Bombardier street  
Boucherville (Quebec) J4B 8P1  
CANADA

Toll Free: 1-800-205-1108  
Fax: 1 450-464-8111  
www.Epurair.com

